

### DESCRIPTION

Industrial triplex car wash pumps a perfect marriage with any vehicle wash system. Belt-driven or direct-drive pumps are specially designed for the purpose of Car Wash equipment and Car Wash supply. Specially designed seals, huge connecting rods, super thick ceramic plungers, premium bearings and forged brass manifold (with a lifetime warranty) insure the pump will give years of continuous, trouble free service. AR heavy-duty car wash pumps provide low maintenance and allow service to be quick and affordable.



### SPECIFICATIONS

MAX GPM .....	4	MAX LMP .....	15
MAX PSI.....	2500	MAX BAR .....	170
POWER EBHP .....	6.5	BORE DIA. MM.....	20
STROKE MM.....	10	WEIGHT LBS.....	32
MAX TEMP .....	140°	OIL CAPACITY.....	32oz
INLET THREAD .....	3/4" F	DISCHARGE THREAD .....	3/8" F

### DIMENSIONS

**CWX** N version  
Solid shaft pump ø 24 mm

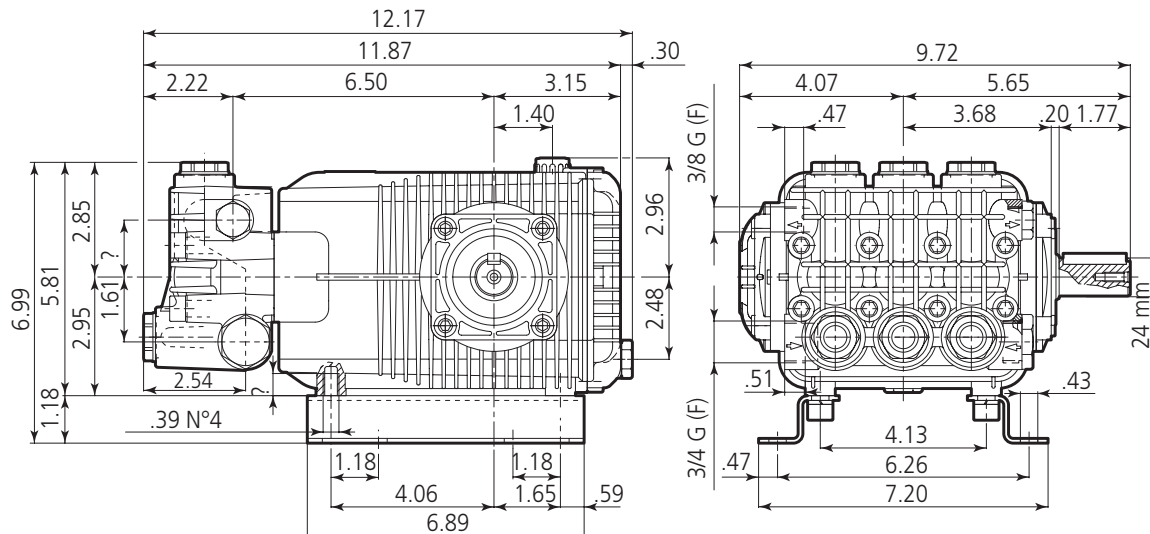

## SPECIAL FEATURES

### WET END

- **Manifold:**
  - **Forged Brass:** Strength and no porosity – long life. Higher hydrostatic pressures – safety, performance.
  - **Inlet and Discharge Ports:** Heavy bosses for added strength.
  - **Offset Discharge Ports:** High efficiency, smooth flow.
  - **Bolts:** Eight bolts, 10mm, grade 8.8.
- **Valves:**
  - **Ultra Form Cages:** Durable, strength, and long life.
  - **Poppets, Seat and Spring:** 303 and 400 series stainless steel.
  - **Valve Caps:** Forged. *PATENTED VALVE CAP DESIGN*
- **Packing and Plungers:**
  - **High Pressure Packing:** "V" style (D-1) Buna-N (cotton duct weave base) strong and tightens under load.
  - **Low Pressure Seals:** "U" cup double lip Buna-N for a good positive seat.
  - **Support and Guides:** Machined brass, 2-piece construction to assure proper plunger alignment and to maximize packing and seal life.
  - **Plungers:** Are a special aluminum oxide blend, solid ceramic for long life, strong durability and more resilient.

### DRIVE END

- **Bearings:** Oversized for maximum life and load disbursement. Premium SKF.
- **Bearing Support:** Precision die-cast and machined to assure concentricity and alignment.
- **Crankcase:** Precision die-cast, large cross head for strength, large cooling fins and anodized (for maximum heat dissipation).
- **Rear Cover:** Precision die-cast, O-ring sealed and bayonet style sight glass for positive sealing and locking (no threads to loosen).

- **Plunger Rods:** Stainless steel construction for strength (no plating to scrape off), back-up and O-ring plunger sealing system.
- **Rod Pins:** Precision ground and hardened steel, oversized for load disbursement.
- **Connecting Rods:** Heavy 2-piece special alloy aluminum based, oversized for maximum strength, load disbursement, and life. Heavy pin area construction, for added load strength.
- **Crankshaft:** Forged, precision ground and hardened for extremely long life and durability.
- **Oil Seals and O-rings:** All are constructed of Buna-N rubber. The O-rings have stainless steel garter springs to assure constant tension on the sealing surface.
- **Oil Capacity:** 32 oz.

### EXTRA FEATURES

- **Dyno Proven:** All pumps are dyno tested to assure the theoretical design meets the actual design.
- **Valve Design:** Each pump series has a valve design that optimizes its highest efficiency.
- **Hot Water:** High temperature kits are available to 180°F. Refer to breakdown.
- **Wet End Repair:** Very simple no special tools required.
- **Design:** Using advanced fluid handling design programs. Overall pump efficiency is increased.